



## **Dual BCD Large Numeric Display**

---

### **Overview**

The Dual BCD Large Numeric Display shows numbers from 00 to 99. Binary Coded Decimal digital inputs from a PLC or switch control the display.

The enclosure mounts easily to any panel. Screw terminal connections provide quick and easy installation.

The direct driving of the display prevents the pulsating effect of some multiplexed displays. High-speed buffers allow for rapid updates that display without “changing blur”, as fast as the eye can see.

The unit is also useful for displaying part pass/fail counts, current draw, angle, distance, cycle step, status codes, and temperature.

Connecting the display in parallel with a thumbwheel or rotary BCD switch will display the switch’s setting.





## Dual BCD Large Numeric Display

---

# Mounting

It is not necessary to remove any of the case screws to install the display.

To mount the display in a panel:

- 1) Remove the slide clips from the display enclosure. Press the clips towards the front of the enclosure. Then lift the clips straight out and away from the side of the enclosure.
- 2) Slide the back of the enclosure into the panel from the panel front.
- 3) Put the side clips back into the enclosure. The Philips head of the screw points towards the back of the case.
- 4) Screw the clips down lightly to tighten them against the back of the front panel.

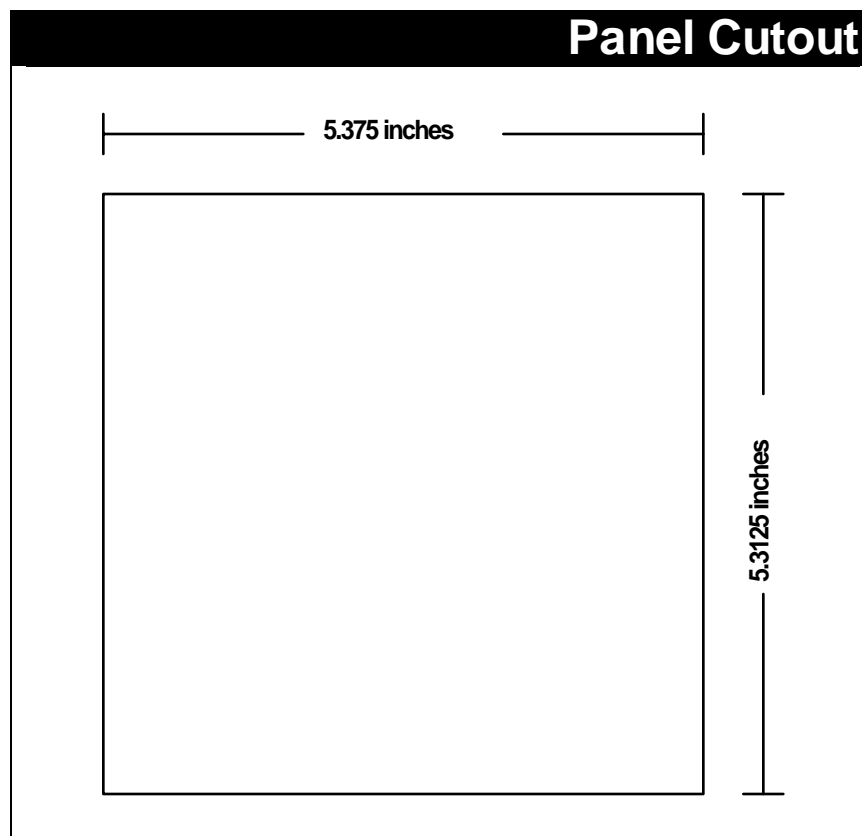



## Dual BCD Large Numeric Display

# Wiring

### Power Supply

Please refer to the drawing Connections for the screw terminal connections.

The power supply required is 24VDC +/- 10% at 0.625A (minimum). The power supply should be clean and free of transients and noise.

The power supply common is isolated from the digital input common.

### Digital Inputs

The digital inputs use positive logic and are active high (true) when the input is between 3.3 and 28 VDC and -3.3 to -28 VDC. Low (false) inputs are below +/-1 VDC.

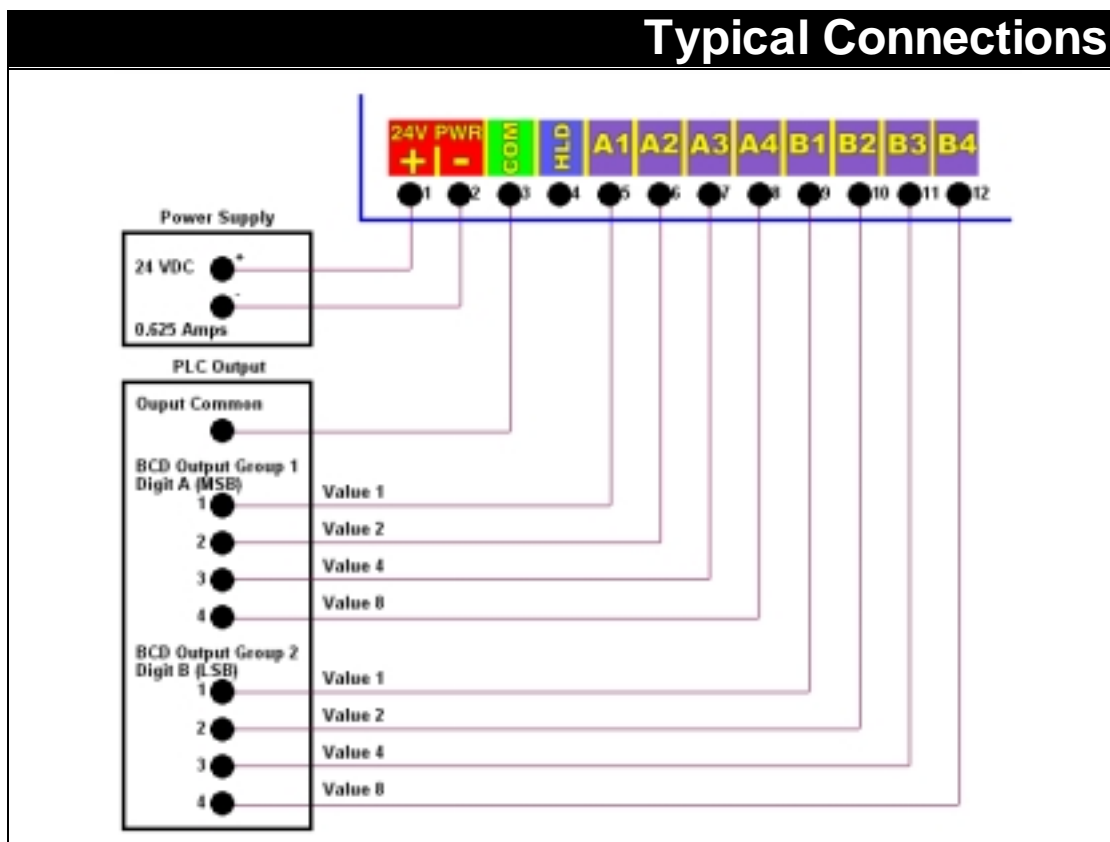



## Dual BCD Large Numeric Display

# Electrical Signals

The digital inputs consist of a 10 KOHM resistor connected in series with a bi-directional photo coupler. The two LEDs in the photo coupler are in parallel and reversed from each other. This allows inputs that are positive or negative.

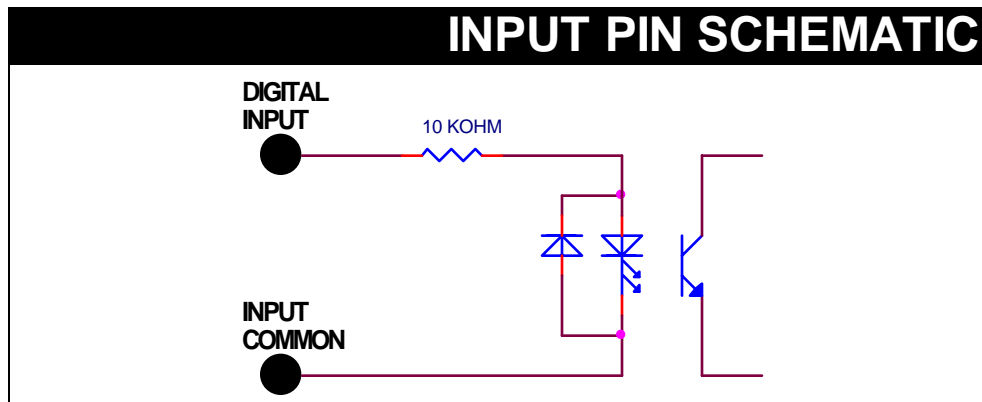

The input wiring will work with most types of digital I/O PLC outputs or mechanical switches.

Sourcing DC from the PLC will provide a positive voltage signal to the display. When the relay or transistor turns on, power provided to the input pin will activate the display.

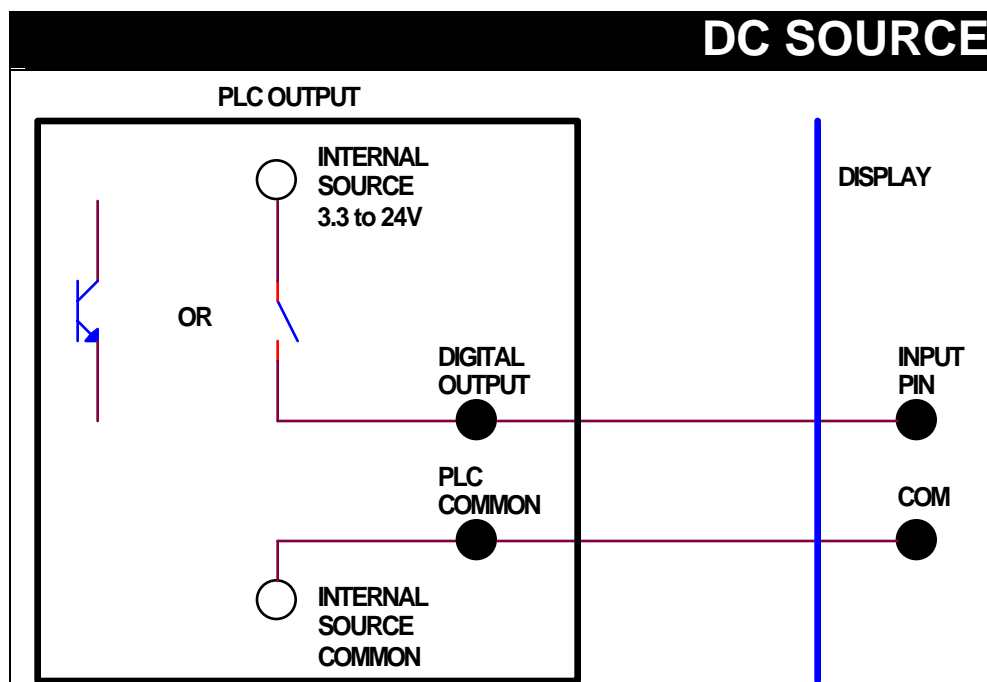



## Dual BCD Large Numeric Display

# Electrical Signals

Sinking DC from the PLC will provide a negative voltage signal to the display. When the relay or transistor turns on, the power common completes the circuit. The input activates when the voltage on the input pin is from  $-3.3$  to  $-24$  volts. The bi-directional input of the display allows this configuration.

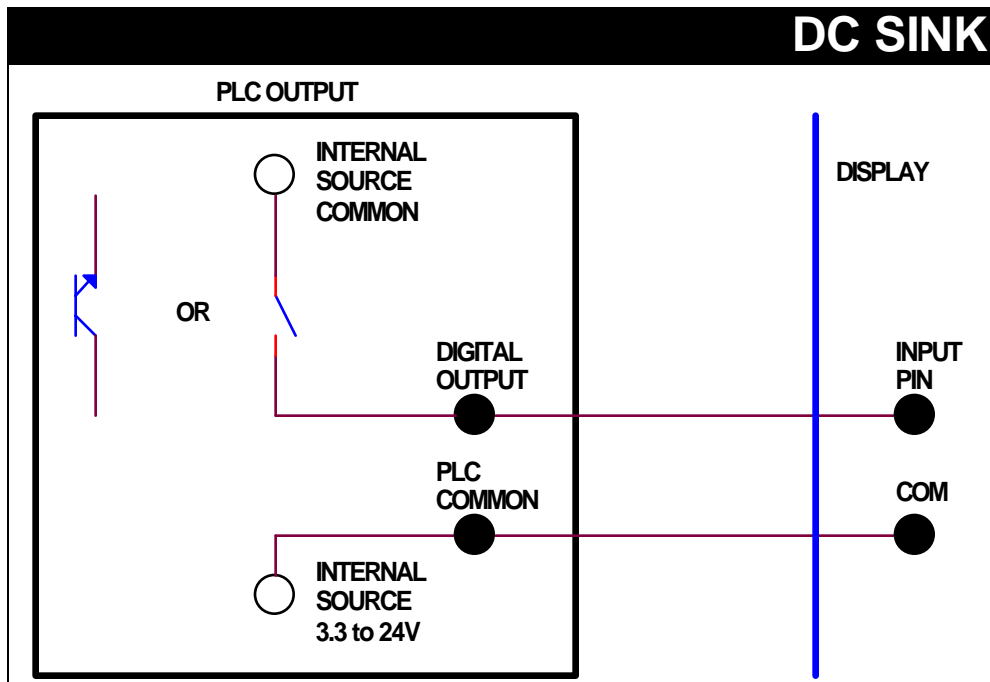



## **Dual BCD Large Numeric Display**

---

# **HOLD Function**

The HOLD function latches the current display. When the HOLD input is on the display locks the current value. The inputs may change and the display will not update. When the HOLD input voltage becomes low, the display will show the current value on the inputs and update as the inputs change.

If you do not need the HOLD function, leave the HOLD terminal disconnected and the display will automatically update.

The HOLD function latches the current value on the inputs when activated. The PLC updates all of its outputs at the same time at the end of its scan of ladder logic. Turning on the HOLD input at the same time as the digital BCD inputs change causes the display to latch the changing inputs. Ensure your program engages the HOLD input one PLC scan cycle later to allow the PLC relays to activate.

If the display shows random numbers when changing from one number to the next, the PLC relays are too slow. The display is seeing the switching of the relays. Use the HOLD function to lock the display during the change.

- 1) 1st scan turns on the HOLD to lock the old value.
- 2) 2nd scan updates the BCD outputs
- 3) 3rd scan turns off the HOLD. The display will show the current value.



## Dual BCD Large Numeric Display

---

# Special Effects

### Leading zero

To remove the leading zero (i.e. **02** changes to **2**), blank the digit A. Activate the blank when the display number is less than 10.

### Hide or turn off the display

To hide the entire display, blank both digits.

### Flash the display

To have the display flash to indicate an alarm condition or problem, use a timer to alternate between blank digits and the current value into both digits.

### How to blank a digit

To blank (turn off) a digit, load an invalid number into the digit. This is any number above nine. There is no method to show numbers above nine without using letters. When a number above nine is loaded into a digit, that digit becomes blank (off).

BCD Number	A4	A3	A2	A1	Display
0	0	0	0	0	0
1	0	0	0	1	1
2	0	0	1	0	2
3	0	0	1	1	3
4	0	1	0	0	4
5	0	1	0	1	5
6	0	1	1	0	6
7	0	1	1	1	7
8	1	0	0	0	8
9	1	0	0	1	9
A (10)	1	0	1	0	Blank
B (11)	1	0	1	1	Blank
C (12)	1	1	0	0	Blank
D (13)	1	1	0	1	Blank
E (14)	1	1	1	0	Blank
F (15)	1	1	1	1	Blank



## Dual BCD Large Numeric Display

# Special Effects

Some PLC systems will allow numbers in the program to output a digit above nine. If the PLC does not allow numbers above nine, use another output in parallel to force a number above nine. This output drives A4 and A3 to load 12 into the BCD input. This causes the first digit to become blank.

Use the same setup to blank digit B.

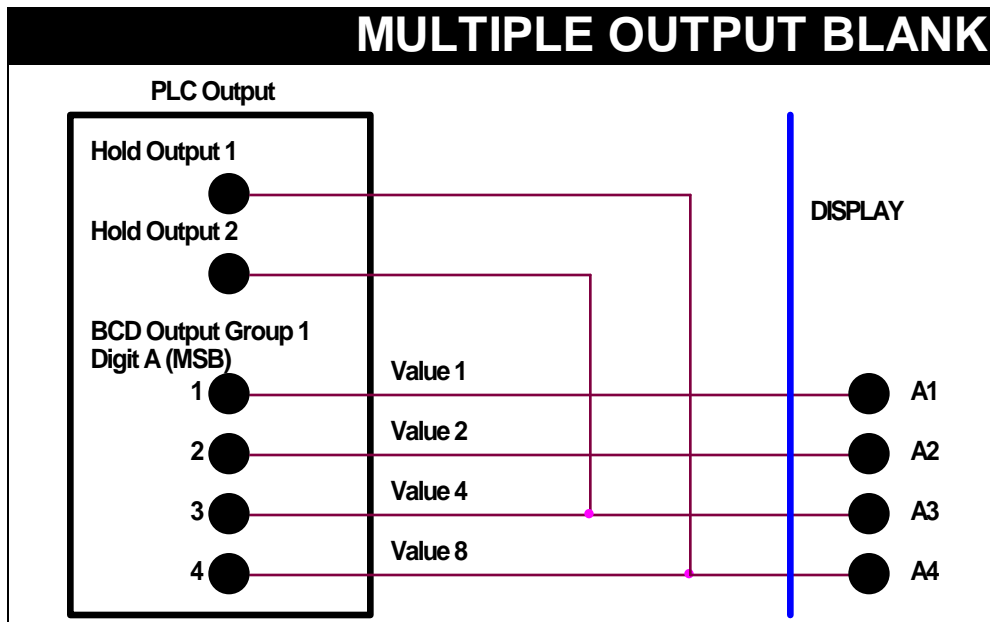

**CAUTION!** Ensure the PLC output can handle having a feedback voltage present on the output from this method.



## Dual BCD Large Numeric Display

# Special Effects

To conserve outputs when blanking a digit, a single output works with two diodes. The diodes prevent A4 and A3 from shorting together.

Use two additional diodes for digit B to blank the second digit as well.

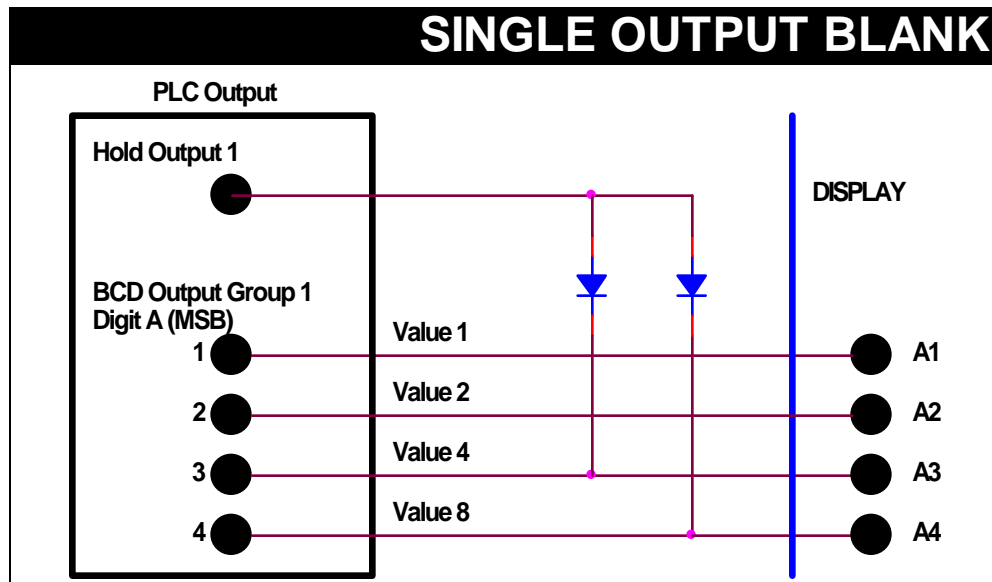

**CAUTION!** Ensure the PLC output can handle having a feedback voltage present on the output from this method.



## Dual BCD Large Numeric Display

---

# What is BCD?

BCD stands for Binary Coded Decimal. Industrial systems use BCD to transmit a number from one device from another. BCD is mostly used with thumbwheel switches and simple displays connected to PLCs and robotic systems.

A single digit (i.e. 4) uses four wires. Each wire has a value or weight to it. The weights are 1, 2, 4, and 8. If the wires with the values of 2 and 4 are on, then the value is  $2 + 4 = 6$ . This is a basic binary system. The table shows each possible value.

BCD Number	A4	A3	A2	A1	Display
0	0	0	0	0	0
1	0	0	0	1	1
2	0	0	1	0	2
3	0	0	1	1	3
4	0	1	0	0	4
5	0	1	0	1	5
6	0	1	1	0	6
7	0	1	1	1	7
8	1	0	0	0	8
9	1	0	0	1	9
A (10)	1	0	1	0	Blank
B (11)	1	0	1	1	Blank
C (12)	1	1	0	0	Blank
D (13)	1	1	0	1	Blank
E (14)	1	1	1	0	Blank
F (15)	1	1	1	1	Blank

With the four wires, 16 different combinations are possible. There are only symbols for 0 to 9 in the decimal number system. This leaves the numbers 10 to 15 unused. Some PLCs will use letters to represent 10 to 15. The display cannot show numbers above nine since it needs to use the second digit. The second BCD input controls the second digit. Each digit has its own four wires.

The unit will blank the display for the numbers 10 to 15. Alternate display models are available that will display all of the characters of the alphabet.



## Dual BCD Large Numeric Display

---

# Troubleshooting

**Q.** The display does nothing. What could be wrong?

**A.** Check the polarity of the input connections. Use a voltage meter to measure the voltage on terminals 1 and 2 of the screw terminal block. Terminal 1 should be positive. The voltage should be from 21.6 VDC to 26.4 VDC. If it is OK, check the fuse.

**Q.** The display still does nothing. What else could be wrong?

**A.** Remove all connections except power and ground. With 24 VDC power and ground in the first two terminals and no wires in any other terminals, the display will display 00.

**Q.** The BCD or output card uses a 5 VDC signal. Will the display work with this?

**A.** The display works with this application. The input will work with any voltage from 3.3 to 28 VDC.

**Q.** The display shows 00 and never changes. What else could be wrong?

**A.** Ensure a 3 to 28 volt signal is present from the PLC to the inputs. Use a voltmeter to measure on the terminal screws from the I/O common to each of the BCD inputs. If you are using the hold function, remove the HOLD wire to test. If the display starts working, check your logic for the HOLD function and review the HOLD section.

**Q.** The unit shows 00 and still does not accept changes from the PLC. How is the display tested to see if it working?

**A.** Remove all wires except power and ground. Jumper ground (pin 2) to the I/O common (pin 3). Jumper power to any BCD input terminal. The display should change. Check each A and B input.